

ET 1600

ET 1600HF

ET 2000



Instruction manual

1 SAFETY	3
2 INTRODUCTION	5
2.1 Equipment	5
3 TECHNICAL DATA	5
4 INSTALLATION	6
4.1 Location	6
4.2 Mains power supply	6
4.2.1 Recommended fuse sizes and minimum cable area	6
5 OPERATION	7
5.1 Connections - ET 1600 and ET 2000	7
5.2 Connections ET 1600HF	8
5.3 Symbols and Control panels	9
5.4 Symbols and Function explanation	10
5.5 MMA welding	11
5.5.1 Welding current setting	11
5.5.2 Arc force	12
5.5.3 Striking the arc	12
5.5.4 Manipulation of electrode	12
5.5.5 Anti-electrode pick-up	12
5.5.6 Joint forms	12
5.5.7 Electrode selection	13
5.6 TIG welding	13
5.6.1 Welding current setting	13
5.6.2 Slope Down (ET 1600HF)	13
5.6.3 Striking the arc	14
5.6.4 Anti-electrode pick-up	14
5.6.5 Joint forms	14
6 MAINTENANCE	14
6.1 Power source	15
6.2 Welding torch	15
7 FAULT-TRACING	15
8 ORDERING	15
DIAGRAM	16
ORDERING NUMBER	18
ACCESSORIES	19

1 SAFETY

Users of ESAB equipment have the ultimate responsibility for ensuring that anyone who works on or near the equipment observes all the relevant safety precautions. Safety precautions must meet the requirements that apply to this type of equipment. The following recommendations should be observed in addition to the standard regulations that apply to the workplace.

All work must be carried out by trained personnel well-acquainted with the operation of the equipment. Incorrect operation of the equipment may lead to hazardous situations which can result in injury to the operator and damage to the equipment.

1. Anyone who uses the equipment must be familiar with:
 - its operation
 - location of emergency stops
 - its function
 - relevant safety precautions
 - welding and cutting
2. The operator must ensure that:
 - no unauthorized person is stationed within the working area of the equipment when it is started up.
 - no-one is unprotected when the arc is struck
3. The workplace must:
 - be suitable for the purpose
 - be free from drafts
4. Personal safety equipment
 - Always wear recommended personal safety equipment, such as safety glasses, flame-proof clothing, safety gloves. **Note!** *Do not use safety gloves when replacing wire.*
 - Do not wear loose-fitting items, such as scarves, bracelets, rings, etc., which could become trapped or cause burns.
5. General precautions
 - Make sure the return cable is connected securely.
 - Work on high voltage equipment **may only be carried out by a qualified electrician.**
 - Appropriate fire extinguishing equipment must be clearly marked and close at hand.
 - Lubrication and maintenance must **not** be carried out on the equipment during operation.



WARNING

Do not use the power source for thawing frozen pipes.



WARNING



Arc welding and cutting can be injurious to yourself and others. Take precautions when welding and cutting. Ask for your employer's safety practices which should be based on manufacturers' hazard data.

ELECTRIC SHOCK - Can kill

- Install and earth the unit in accordance with applicable standards.
- Do not touch live electrical parts or electrodes with bare skin, wet gloves or wet clothing.
- Insulate yourself from earth and the workpiece.
- Ensure your working stance is safe.

FUMES AND GASES - Can be dangerous to health

- Keep your head out of the fumes.
- Use ventilation, extraction at the arc, or both, to take fumes and gases away from your breathing zone and the general area.

ARC RAYS - Can injure eyes and burn skin.

- Protect your eyes and body. Use the correct welding screen and filter lens and wear protective clothing.
- Protect bystanders with suitable screens or curtains.

FIRE HAZARD

- Sparks (spatter) can cause fire. Make sure therefore that there are no inflammable materials nearby.

NOISE - Excessive noise can damage hearing

- Protect your ears. Use earmuffs or other hearing protection.
- Warn bystanders of the risk.

MALFUNCTION - Call for expert assistance in the event of malfunction.

Read and understand the instruction manual before installing or operating.

PROTECT YOURSELF AND OTHERS!



CAUTION

Read and understand the instruction manual before installing or operating.

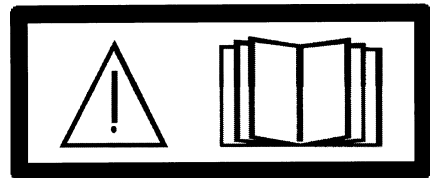

CAUTION

This product is solely intended for arc welding.

ESAB can provide you with all necessary welding protection and accessories.

2 INTRODUCTION

ET 1600 and **ET 2000** are welding power sources intended for use with coated electrodes (MMA welding) and TIG welding (Lift Arc).

ET 1600HF is an HF TIG power source offering also MMA capability.

ESAB's accessories for the product can be found on page 19.

2.1 Equipment

The power source is supplied with:

- 3 meter welding cable with electrode holder
- 3 meter return cable with return clamp
- ET 17 torch, 4 meter (*only valid for ET 1600HF*)
- instruction manual

3 TECHNICAL DATA

	ET 1600	ET 1600HF	ET 2000
Mains voltage	220 / 230 ± 10%, 1~ 50/60 Hz	220 / 230 ± 10%, 1~ 50/60 Hz	220 ± 10%, 1~ 50/60 Hz
Primary current I_{max}	35 A	23 A	46 A
Setting range	5 A / 20.2 V - 165 A / 26.6 V	5 A / 10 V - 160 A / 16.4 V	5 A / 20.2 V - 210 A / 28.4 V
Permissible load at			
25 % duty cycle	-	160 A / 16.4 V	-
35 % duty cycle	160 A / 26.4 V	-	200 A / 26.4 V
60 % duty cycle	130 A / 25.2 V	100 A / 14 V	135 A / 25.4 V
100 % duty cycle	100 A / 24.0 V	80 A / 13 V	120 A / 24.8 V
Power factor at maximum current	0.72	0.75	0.71
Efficiency at maximum current	> 80 %	> 80 %	> 80 %
Open-circuit voltage U ₀ max	59 V	58 V	60 V
Operating temperature	-10 to +40° C	-10 to +40° C	-10 to +40° C
Sound pressure at no-load	<70 db (A)	<70 db (A)	<70 db (A)
Dimensions l x w x h	310 x 140 x 230 mm	400 x 140 x 230 mm	360 x 140 x 230 mm
Weight	6 kg	7.5 kg	7.5 kg
Enclosure class	IP 21S	IP 21S	IP 21S
Application class	S	S	S

Duty cycle

The duty cycle refers to the time as a percentage of a ten-minute period that you can weld or cut at a certain load without overloading. The duty cycle is valid for 40° C.

Enclosure class

The IP code indicates the enclosure class, i. e. the degree of protection against penetration by solid objects or water. Apparatus marked **IP21** are intended for indoor use.

Application class

The symbol **S** indicates that the power source is designed for use in areas with increased electrical hazard.

4 INSTALLATION

The installation must be executed by a professional.

4.1 Location

Position the power source such that its cooling air inlets and outlets are not obstructed.

4.2 Mains power supply

Make sure that the welding power source is connected to the correct supply voltage and that it is protected by the correct fuse rating. The outlet shall have a protective earth connection.

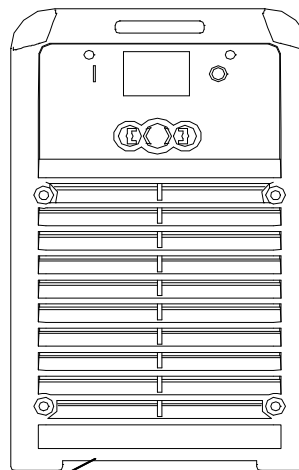

Rating plate with supply connection data

4.2.1 Recommended fuse sizes and minimum cable area

	ET 1600	ET 1600HF	ET 2000
Mains voltage	230V ± 10%, 1 ~ -50/ 60 Hz	230V ± 10%, 1 ~ -50/ 60 Hz	220V ± 10%, 1 ~ - 50/60 Hz
Mains cable area mm²	3 G 2.5	3 G 2.5	3 G 2.5
Phase current I_{1eff}	16 A	16 A	16 A

NOTE! Use the welding power source in accordance with the relevant national regulations.

5 OPERATION

General safety regulations for the handling of the equipment can be found on page 3. Read through before you start using the equipment!

5.1 Connections - ET 1600 and ET 2000

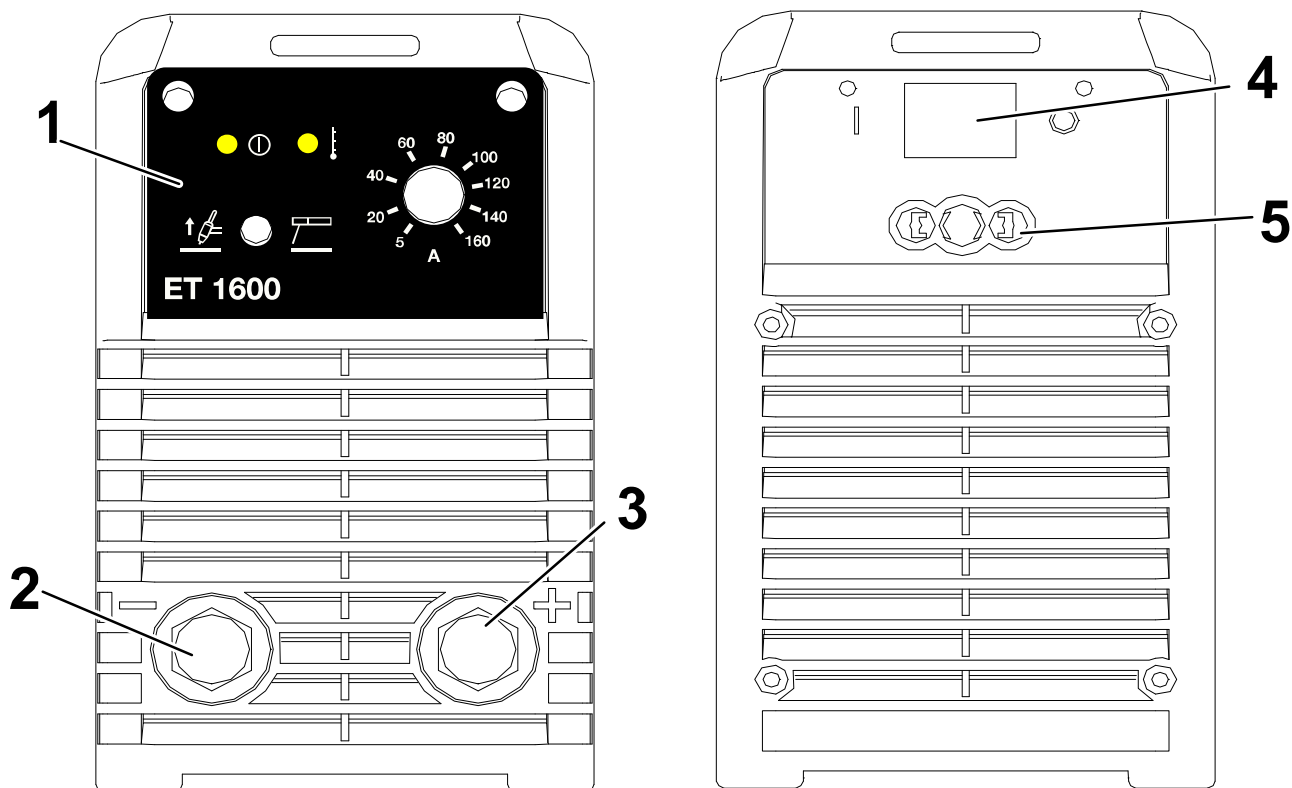

- | | | | |
|---|---|---|-------------------------------|
| 1 | Control panel (ET 1600 and ET 2000) | 4 | Mains power supply switch 1/0 |
| 2 | Connection (-) for return cable, welding cable or TIG torch | 5 | Connection for mains cable |
| 3 | Connection (+) for return cable or welding cable | | |

Connection of welding and return cable ET 1600 and ET 2000

The power source has two outputs, a negative [-] terminal (2) and a positive [+] terminal (3).

For MMA (SMAW) process the output to which the welding cable is connected depends on the type of electrode, please refer to electrode packaging for information relating to the correct electrode polarity.

For optional TIG (GTAW) process, connect the TIG torch power cable to the negative [-] terminal (2). Connect gas inlet nut to a regulated shielding gas supply.

Connect the return cable to the remaining welding terminal on the power source. Secure the return cable's contact clamp to the work piece and ensure that there is good contact.

5.2 Connections ET 1600HF

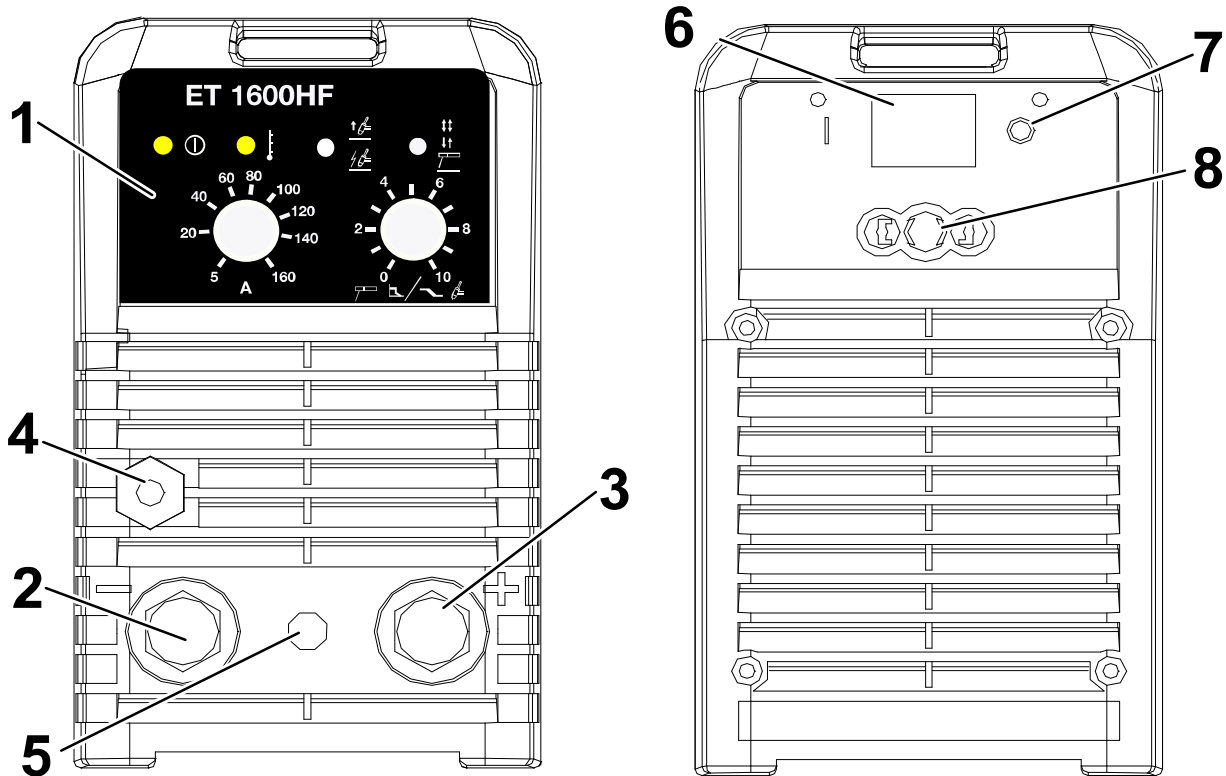

- | | | | |
|---|--|---|-------------------------------|
| 1 | Control panel (ET 1600 HF) | 5 | Connection to the TIG torch |
| 2 | Connection (-) for return cable or welding cable | 6 | Mains power supply switch 1/O |
| 3 | Connection (+) for return cable or welding cable | 7 | Connection for shielding gas |
| 4 | Connection for TIG torch (shielding gas) | 8 | Connection for mains cable |

Connection of TIG torch, electrode and return cables: ET 1600HF

The power source has two outputs, a negative [-] terminal (2) and a positive [+] terminal (3).

For TIG (GTAW) process, connect the TIG torch power cable to the negative [-] terminal (2). Connect the gas inlet nut to the panel mounted gas outlet fitting (4). Connect the TIG torch trigger plug to the panel mounted remote receptacle (5).

For MMA (SMAW) process the output to which the welding cable is connected depends on the type of electrode, please refer to electrode packaging for information relating to the correct electrode polarity.

Connect the return cable to the remaining welding terminal on the power source. Secure the return cable's contact clamp to the work piece and ensure that there is good contact.



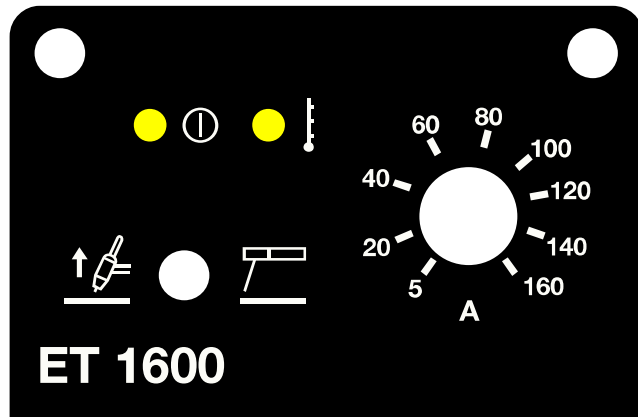

5.3 Symbols and Control panels

ET 1600

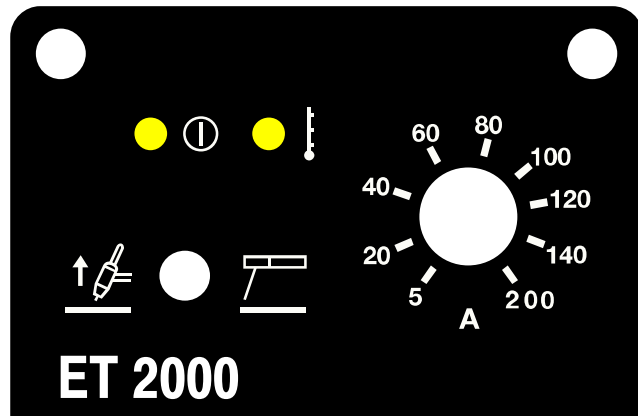

ET 2000



	Power ON Indicating lamp, white, power supply ON		Overheating Indicating lamp, yellow, overheating
	Lift Arc (Live Arc)		MMA welding

ET 1600 HF

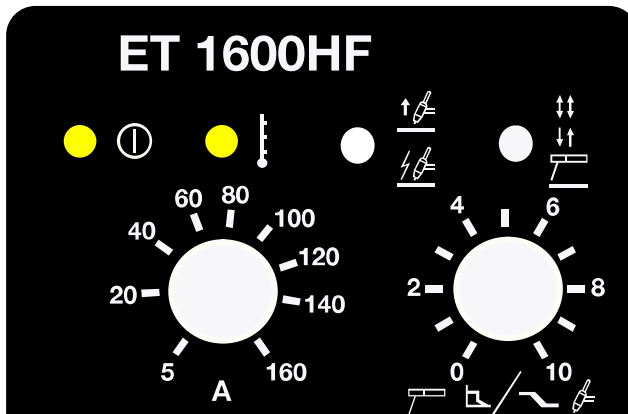

	Power ON Indicating lamp, white, power supply ON		Overheating Indicating lamp, yellow, overheating
	Lift Arc (Live Arc)		HF start
	4-stroke		2-stroke
	MMA welding		Arc force
	Slope down		Tig HF

5.4 Symbols and Function explanation



Overheating protection

The welding power source has a thermal overload trip which operates if the temperature becomes too high, interrupting the welding current and lighting a yellow indicating lamp on the front of the power source. The thermal overload trip resets automatically when the temperature has fallen.



HF start

The HF start function strikes the arc by means of a spark from the electrode to the workpiece as the electrode is brought closer to the workpiece.



4-stroke

In the 4 stroke control mode, pressing the TIG torch trigger switch starts gas pre-flow (if used). At the end of the gas pre-flow time, the current rises to the pilot current (a few ampere), and the arc is struck. Releasing the trigger switch increases the current to the set value (with slope up, if in use). When the trigger switch is pressed in the current returns to the set pilot current (with "slope down" if in use). When the trigger switch is released again the arc is extinguished and any gas post flow occurs.



2-stroke

In the 2 stroke control mode, pressing the TIG torch trigger switch starts gas pre-flow (if used) and strikes the arc. The current rises to the set value (as controlled by the slope up function, if in operation). Releasing the trigger switch reduces the current (or starts slope down if in operation) and extinguishes the arc. Gas post-flow follows if it is in operation.



MMA welding

MMA welding may also be referred to as welding with coated electrodes. Striking the arc melts the electrode, and its coating forms protective slag.



Slope down

TIG welding uses "slope down", by which the current falls 'slowly' over a controlled time, to avoid craters and/or cracks, when a weld is finished.



Arc force

The arc force is important in determining how the current changes in response to a change in the arc length. A lower value gives a calmer arc with less spatter.

5.5 MMA welding

Move process selector switch to desired welding process. NOTE: Power source output is enabled.

Check welding cable polarity selection matches electrode requirements. Select desired welding current level.

5.5.1 Welding current setting

The **ET 1600** and **ET 1600HF** power sources have a adjustable welding current from 5 to 160 Amps while the **ET 2000** has a adjustable value reaching from 5 to 200 Amps.

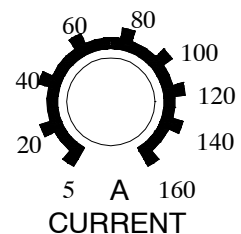

5.5.2 Arc force

When choosing MMA welding, this knob is used to adjust the arc force.

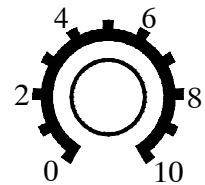

ARC FORCE(MMA)
SLOPE DOWN (TIG)

5.5.3 Striking the arc

MMA welding may also be referred to as welding with coated electrodes. Striking the arc melts the electrode, and its coating forms protective slag.

If, when striking the arc, the tip of the electrode is pressed against the metal, it immediately melts and sticks to the metal, rendering continued welding impossible. Therefore, the arc has to be struck in the same way that you would light a match. Quickly strike the electrode against the metal and then raise it to give an appropriate arc length (approx. 2 mm). If the arc is too long, it will crackle and split before finally going out completely. Once the arc has been struck, move the electrode from left to right. The electrode should be at an angle of 60° to the metal.

5.5.4 Manipulation of electrode

In MMA welding, there are three motions to be matched in the end of electrode: the electrode moving to the molten pool along axes [1]; a small oscillation maybe necessary to achieve the desired width of the melt pool [2]; the electrode moving along welding way [3].

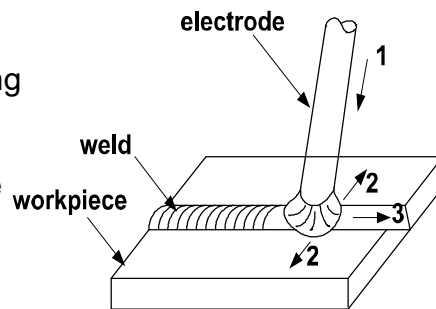

- 1 electrode moving
- 2 the electrode oscillation (right & left)
- 3 the electrode move along weld

The operator can choose the manipulation of electrode based on welding joint sharp, welding position, electrode spec, welding current and operation skill, etc.

5.5.5 Anti-electrode pick-up

If, during the welding, the electrode would get in direct contact (touching) with the workpiece to form short circuit the welding current will drop to a minimum to prolong the life of the electrode.

5.5.6 Joint forms

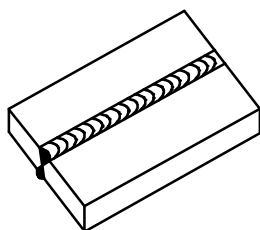

Butt joint

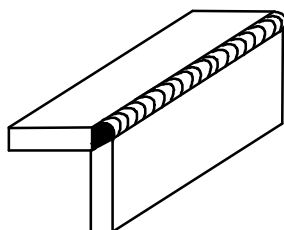

Corner joint

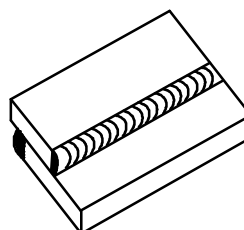

Lap joint

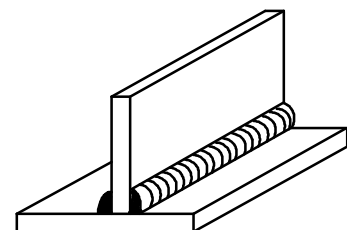

T joint

The common basic joint form: butt joint, corner joint, lap joint & T joint.

5.5.7 Electrode selection

The selection of the right electrode diameter should be based on the thickness of the work piece, the welding position, the type of joint etc. Please refer to the recommendations on the electrode package for further details.

- To ensure good quality weld, the electrode should always be dried or dry stored. This to avoid hydrogen inclusion, blowhols and cold cracks.
- In the welding process, the arc must not be too long; otherwise, it will cause unstable arc burning, large spatter, light penetration, undercut, blowhole, etc. If the arc is too short, it will cause electrode stick.
- In MMA welding the arc length is usually equal to 0.5-1.0 time of the electrode diameter. The basic electrode's arc length is not beyond the electrode diameter, it's better to choose the short arc welding; the acid electrode's arc length is equal to the electrode diameter.

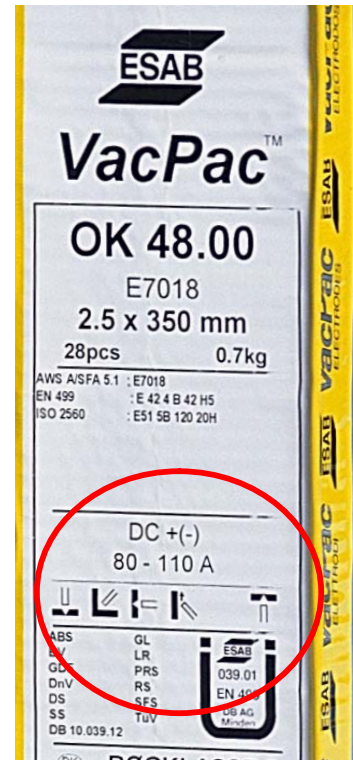

5.6 TIG welding

Move process selector switch to desired welding process.

NOTE: Power source output is enabled.

Check welding cable and TIG torch polarity matches electrode requirements.

Select desired welding current level.

5.6.1 Welding current setting

The **ET 1600** and **ET 1600HF** power sources have a adjustable welding current from 5 to 160 Amps while the **ET 2000** has a adjustable value reaching from 5 to 200 Amps.

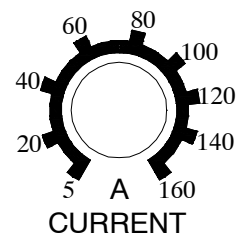

5.6.2 Slope Down (ET 1600HF)

When choosing TIG welding, this knob is used to adjust the slope down time from 0-10 seconds.

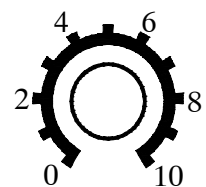

ARC FORCE(MMA)
SLOPE DOWN (TIG)

5.6.3 Striking the arc

HF arc (ET 1600HF only)

The HF function strikes the arc by means of a spark from the electrode to the work piece as the electrode is brought closer to the work piece. Position the electrode on a suitable distance from the work piece and push the trigger.

Lift Arc (Live Arc)

Touch the tungsten to work piece. The power source will generate a low current which will create an arc when the tungsten is lifted from the work piece. To extinguish the arc pull torch away from work piece.

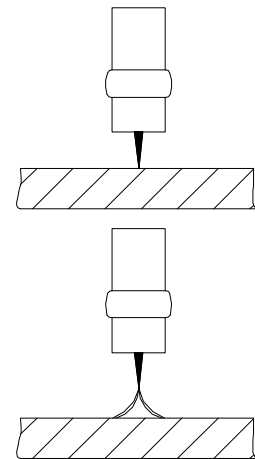

5.6.4 Anti-electrode pick-up

If, during welding, the tungsten electrode would get in direct contact (touching) with the work piece to form a short circuit the welding current will drop to a minimum to prolong the life of the electrode.

5.6.5 Joint forms

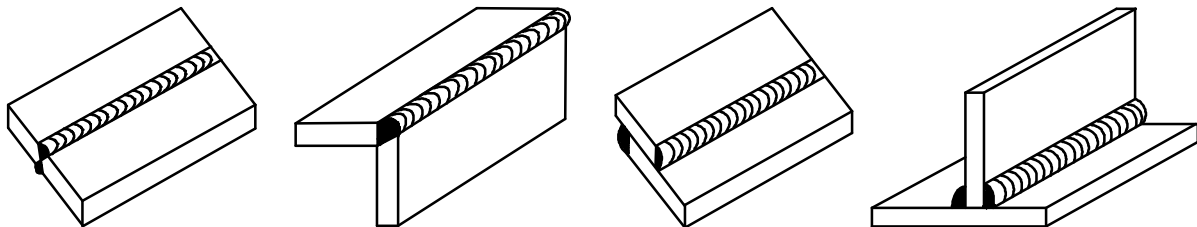

Butt joint

Corner joint

Lap joint

T joint

The common basic joint form: butt joint, corner joint, lap joint & T joint.

6 MAINTENANCE

Regular maintenance is important for safe, reliable operation.

Only those persons who have appropriate electrical knowledge (authorized personnel) may remove the safety plates.



CAUTION

All guarantee undertakings from the supplier cease to apply if the customer himself attempts any work in the product during the guarantee period in order to rectify any faults.

6.1 Power source

Check regularly that the welding power source is not clogged with dirt.

How often and which cleaning methods apply depend on:

- welding process
- arc time
- placement
- surrounding environment

It is normally sufficient to blow the power source with dry compressed air (reduced pressure) once a year.

Clogged or blocked air inlets and outlets otherwise result in overheating.

6.2 Welding torch

Wear parts should be cleaned and replaced at regular intervals in order to achieve trouble-free welding.

7 FAULT-TRACING

Try these recommended checks and inspections before sending for an authorized service technician.

Type of fault	Corrective action
No arc.	<ul style="list-style-type: none"> • Check that the mains power supply switch is turned on. • Check that the welding current supply and return cables are correctly connected. • Check that the correct current value is set. • Check to see whether the MCB has tripped.
The welding current is interrupted during welding.	<ul style="list-style-type: none"> • Check whether the thermal cut-outs have tripped (indicated by the orange lamp on the front panel). • Check the mains power supply fuses.
The thermal cut-out trips frequently.	<ul style="list-style-type: none"> • Check to see whether the dust filter is clogged. • Make sure that you are not exceeding the rated data for the power source (i.e. that the unit is not being overloaded).
Poor welding performance.	<ul style="list-style-type: none"> • Check that the welding current supply and return cables are correctly connected. • Check that the correct current value is set. • Check that the correct electrodes are being used. • Check the gas flow.

8 ORDERING

Repair and electrical work should be performed by an authorized ESAB serviceman. Use only ESAB original spare and wear parts.

Spare parts may be ordered through your nearest ESAB dealer, see the last page of this publication.

Diagram

ET 1600 & ET 2000

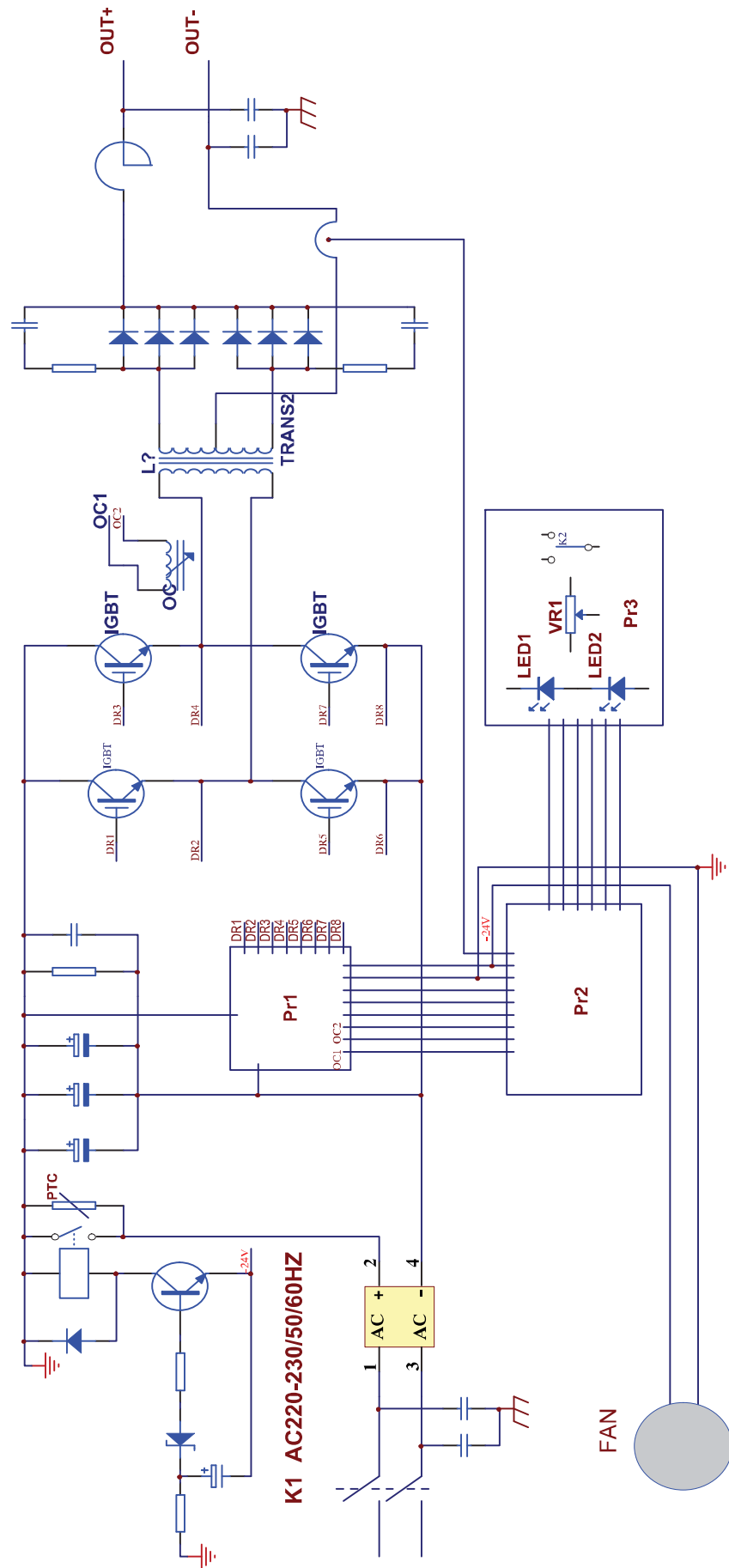

ET 1600HF

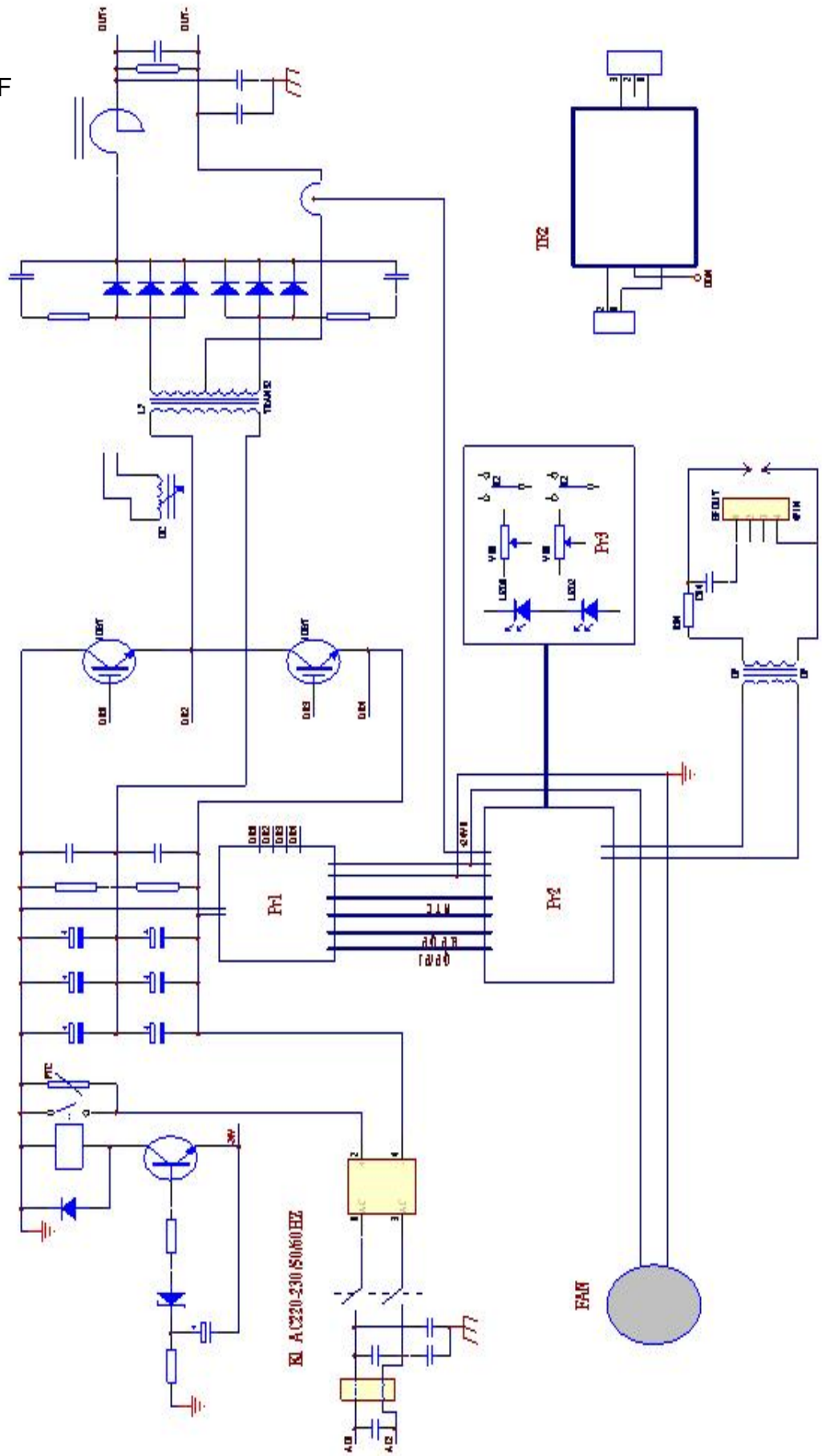

ET 1600, ET 1600HF, ET 2000

Ordering number



Ordering no.	Description	Type
0700 300 881	Welding power source	ET 1600
0700 300 882	Welding power source	ET 1600HF
0700 300 883	Welding power source	ET 2000
0459 839 054	Spare parts list	ET 1600, ET 1600HF and ET 2000

The spare parts list is available on the Internet at www.esab.com

Accessories

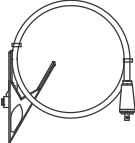
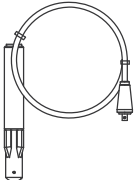
	<p>Return cable with clamp 0700 300 863 3 m 16 mm²</p>
	<p>Welding cable with electrode holder 0700 300 862 3 m 16 mm²</p>
	<p>TIG torch 17, 4 m 0700 300 860 (for ET 1600HF only)</p>
	<p>TIG torch 17v, 4 m 0700 300 861 (for ET 1600 & ET 2000 only)</p>

ESAB subsidiaries and representative offices

South America

ARGENTINA

CONARCO
Buenos Aires
Tel: +54 11 4 753 4039
Fax: +54 11 4 753 6313

BRAZIL

ESAB S.A.
Contagem-MG
Tel: +55 31 2191 4333
Fax: +55 31 2191 4440

Asia/Pacific

CHINA

Shanghai ESAB A/P
Shanghai
Tel: +86 21 2326 3000
Fax: +86 21 6566 6622

INDIA

ESAB India Ltd
Calcutta
Tel: +91 33 478 45 17
Fax: +91 33 468 18 80

INDONESIA

P.T. ESABindo Pratama
Jakarta
Tel: +62 21 460 0188
Fax: +62 21 461 2929

JAPAN

ESAB Japan
Tokyo
Tel: +81 45 670 7073
Fax: +81 45 670 7001

MALAYSIA

ESAB (Malaysia) Snd Bhd
USJ
Tel: +603 8023 7835
Fax: +603 8023 0225

SINGAPORE

ESAB Asia/Pacific Pte Ltd
Singapore
Tel: +65 6861 43 22
Fax: +65 6861 31 95

SOUTH KOREA

ESAB SeAH Corporation
Kyungnam
Tel: +82 55 269 8170
Fax: +82 55 289 8864

UNITED ARAB EMIRATES

ESAB Middle East FZE
Dubai
Tel: +971 4 887 21 11
Fax: +971 4 887 22 63

Africa

EGYPT

ESAB Egypt
Dokki-Cairo
Tel: +20 2 390 96 69
Fax: +20 2 393 32 13

SOUTH AFRICA

ESAB Africa Welding & Cutting Ltd
Durbanville 7570 - Cape Town
Tel: +27 21 975 8924

Distributors

For addresses and phone numbers to our distributors in other countries, please visit our home page

www.esab.com

